

GULFTRONIC INFLOW SYSTEM

ON-LINE PARTICLE SENSOR SYSTEM



The Gulftronic® Inflow™ vision-based camera and image processing system provides customers with continuous, real-time viewing and analysis capabilities to determine concentration, particle size and count of particulates in the process stream under process conditions.



GULFTRONIC INFLOW SYSTEM

SYSTEM CAPABILITIES

- In-line, real-time view and analysis of oil, water, sand, and gas
- Automation and real-time control of backflush or separation stages
- Accurate measurement of particle view, size/shape, count, and concentration
- Gallons per minute flow rates
- Live video data analysis
- Reduces analysis wait time for operators
- Record, save video for future analysis
- Measure and control process parameters
- Measure sub-micron sized particles

Whether in a lab environment, at-line, or in-line, the Gulftronic Inflow system accurately measures multiple aspects of water, oil, solids, and gas in a process stream, allowing customers to create more precise data analysis. Current fluorescence monitors only measure oil and are affected by solids and gas in the stream. The Gulftronic Inflow system, however, conveniently identifies the differences and enables customers to quickly and visually verify the readings. The Gulftronic Inflow system can also be calibrated with a customer's current lab method to support easy field calibration.

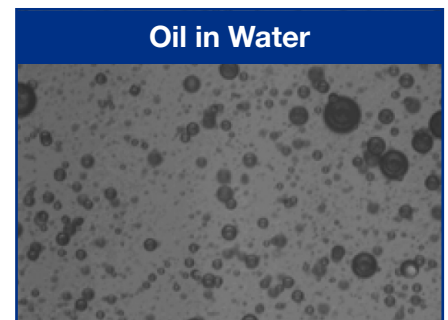
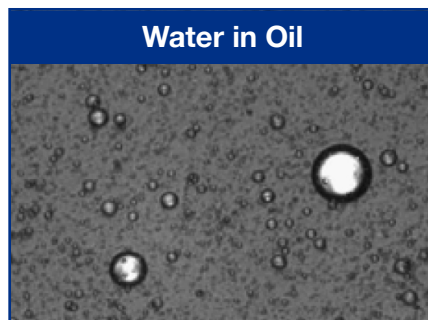
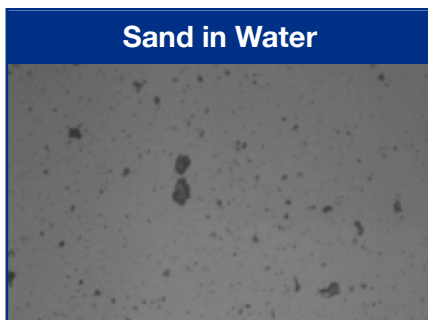

FEATURES

- PPM/PPB values
- Particle size distribution of oil/sand
- 10 ft/s flow velocity
- Real time analysis, visual verification
- Easy to use for operators and lab
- Eliminate errors associated with florescence
- Particle size = .7 microns and greater
- Complete skid mount design
- Store data in excel or a database
- Not affected by gas or solids

The Gulftronic Inflow system helps determine PPM in the inlet and outlet of a separator to optimize the skid. For chemical companies, the Gulftronic Inflow system immediately indicates whether the chemicals being injected are agglomerating the oil. When used with Gulftronic Electrostatic Separators, the Gulftronic Inflow system can accurately measure the particle size distribution and concentration of the output quality. This provides operators with real-time data on product clarity to help reduce off-spec product.

In-line analysis ensures production samples are not skipped over due to sample analysis wait times. Each sample setting can be saved, providing convenient, repeatable system set-up. A video recording option provides access to imagery for additional review and analysis at a later time.

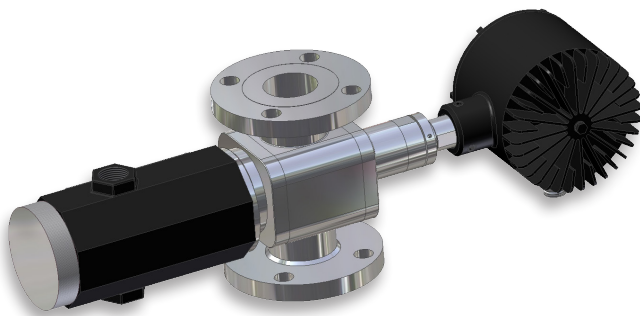

IN-LINE SENSOR WITH CAMERA AND LIGHT



IMAGE PROCESSING SYSTEM

GULFTRONIC INFLOW

GULFTRONIC INFLOW SYSTEM PACKAGE CONTENTS

- Two 2" 300# Gulftronic Inflow Cameras
 - Camera Power: 120 VAC / 60 Hz (230 VAC / 50 Hz)
 - Ethernet Camera Connectivity
- Image Processing System
 - Vector Control Module installed with Gulftronic Inflow software
 - Microsoft Windows Based Operating System
 - Ethernet OPC or 4-20 mA Devices

PACKAGE PART NUMBERS AND SPECIFICATIONS

Part Number	Rating	Temp. Range	Flange Range	Lens View Area	Electrical Input	Strobe Light	No Spray Rings	Eth. CCD Part #	Counters	Seals
VD4912-1043	Explosion Proof Rated (EXP)	0° - 80° C	300#	1-4 MPP	120V AC	X	X	V006-32	X	VITON
VD4912-1047	Explosion Proof Rated (EXP)	80° - 204° C	300#	1-4 MPP	120V AC	X	X	V006-32	X	VITON
VD4912-1049	Explosion Proof Rated (EXP)	0° - 80° C	300#	1-4 MPP	230V AC	X	X	V006-32	X	VITON
VD4912-1050	Explosion Proof Rated (EXP)	80° - 204° C	300#	1-4 MPP	230V AC	X	X	V006-32	X	VITON